

DROP

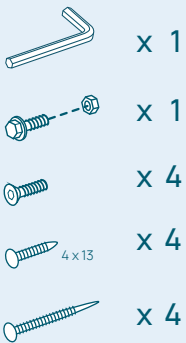

Made in Estonia, EU

info@huum.eu
huum.eu
#huumsauna

HUUM OÜ
Vahi tee 9, Tartumaa
60534, Estonia

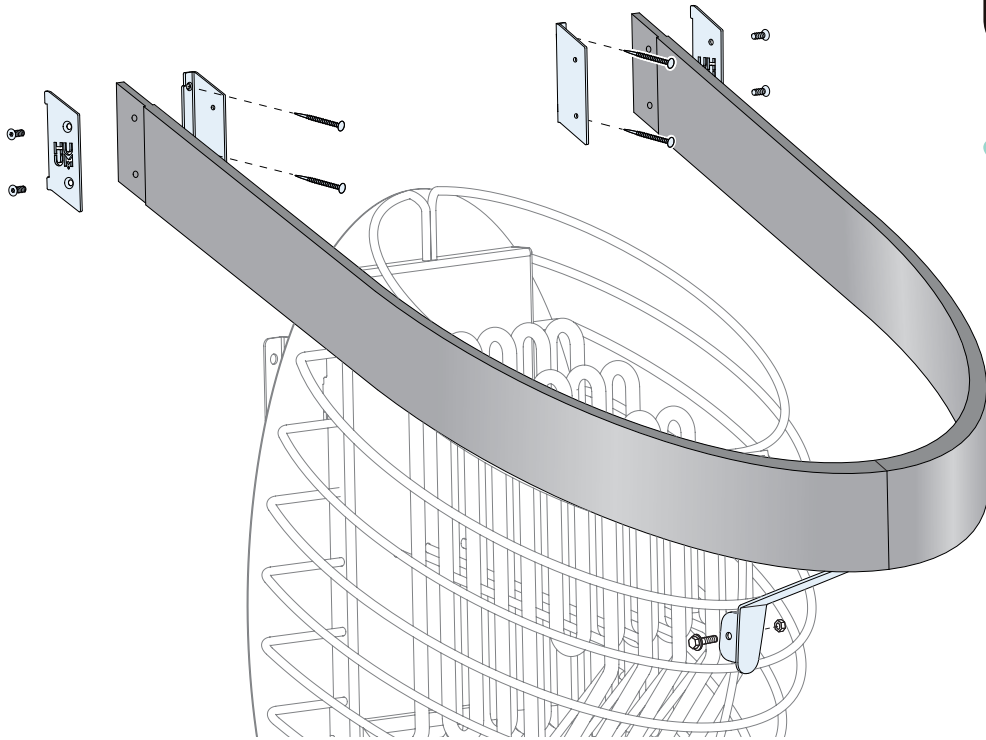

♥ OF SAUNA

Tutorial
video



EE Kaitsepiire

- Ühenda poolkaared omavahel kronsteiniga, kasutades nelja kruvi (4x13mm), et moodustuks terviklik piire.
- Aseta puitpiire DROP kerisele nii, et kronstein jääb kerise esiküljel **ülevaolt kolmandasse vahesse** (3. ja 4. ribi vahele) ja paigutub tihkelt ümber püstise ribi.
- Kinnita kronstein poldi ja mutriga.
- Veendu, et kaare otsad oleks loodis.
- Märgista kohad, kus piire puudutab sein.
- Eemalda kaitsepiire kerise küljest.
- Paiguta metallist kronsteinid seinale märgitud kohtadesse ja tähistage kruviavad.
- Puuri märgitud kohtadesse **ø2mm** augud.
- Kinnita metallist kronsteinid seinale, kasutades selleks kahte pikemat kruvi ühe kronsteini kohta.
- Paigalda kaitsepiire tagasi kerise külge.
- Paigalda välimised kinnitusplaadid.
- Kinnita kinnitusplaadid kasutades selleks kaasas olevat kruvi. **Valmis!**

NB! Kaasasolevad pikemad kruvid on üldkruvid. Vajadusel pea spetsialistiga nõu, kas need sobivad sinu seinale.

NB! Et kaitsta niiskuse ja kuumuse eest, töödelge kõik puidust osad kuumakindla ja mittetoksilise puidukaitsevahendiga, et vältida kõverdumist, pragunemist ja lagunemist. **Parima kaitse tagamiseks korrake töötlemist vähemalt kord aastas.**

Leia ajakohasem materjal meie kodulehelt: huum.eu

EN Safety Railing

- Connect wooden arches to the support with four smallest screws to form a complete railing.
- Place the railing on the DROP heater grates in **the third gap from the top** so that the frontal vertical rod is between the support.
- Fasten the support with a bolt and a nut.
- Level the safety railing.
- Mark the spots where railing touches the wall.
- Remove the railing.
- Place the supports to the marked spots and mark the screw openings
- Drill **ø2 mm** holes to the marked spots on the wall.
- Install the supports to the wall using two screws each.
- Install the railing back on the DROP.
- Install the outside support plates.
- Fix the plates using the remaining screws as shown.
- You are now safe to use the **HUUM DROP** sauna heater!

ATTENTION! The included longer screws are general purpose screws. If necessary, consult a specialist to see if these fit your wall.

ATTENTION! To protect against moisture and heat, treat all wooden parts with a heat-resistant, non-toxic wood preservative to prevent warping, cracking, and decay. **For lasting protection, reapply at least once a year.**

Find the latest updates on our website: huum.eu